



Technical Specification

BOOTED SMT LED WL-L2017B70C-003 Blue/White

Features

- White package.
- Optical indicator.
- Ideal for backlight and light pipe application.
- Inter reflector.
- Wide viewing angle.
- Compatible with automatic placement equipment.
- Suitable for vapor-phase reflow, infrared reflow and wave solder processes.
- Available on tape and reel (8mm tape).

Description

This LED/boot assembly provides precise color matching to specific x and y coordinates. Due to package design, this assembly has a wide viewing angle for optimized light coupling.

Applications

- Aerospace: backlight for panels, LCD's, switches and symbols.
- Automotive: backlight in dashboards and switches

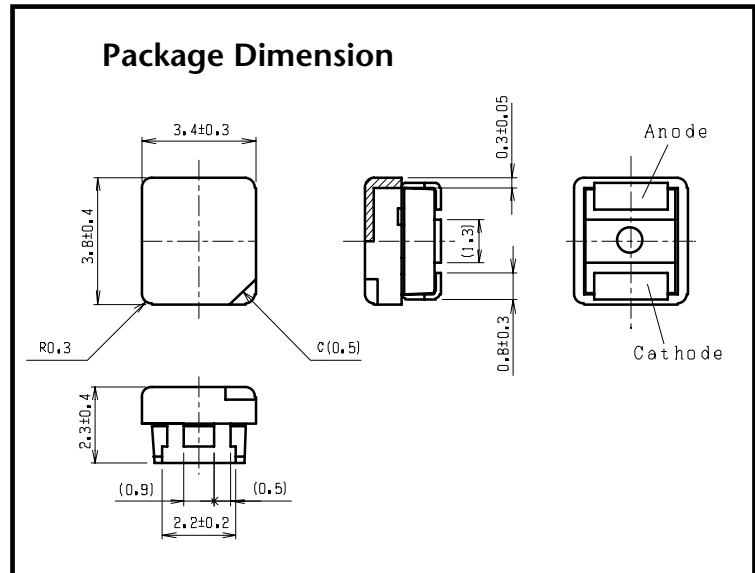

Notes

- Tolerances are ± 0.1 mm unless otherwise stated.
- Unit = mm.

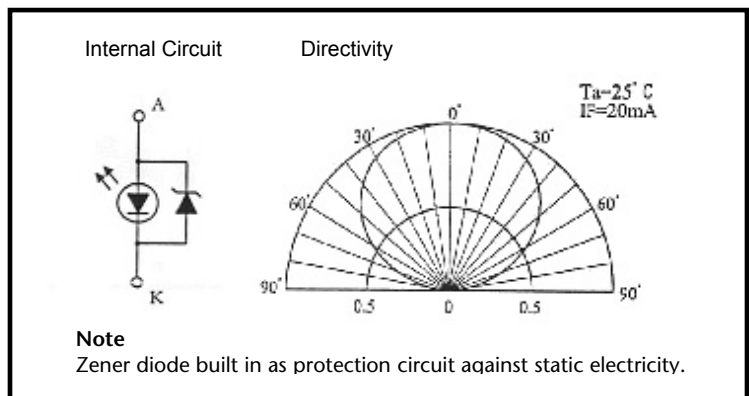

Part Number	Chip		Boot Color	Revision
	Material	Emitted Color		
WL-L2017B70C-003	InGaN/SiC	Blue/White	Orange	1.1



Technical Specification

BOOTED SMT LED WL-L2017B70C-003 Blue/White

Absolute Maximum Ratings at Ta = 25°C

Symbol	Parameter	Rating	Unit
If	Forward Current	30	mA
Topr	Operating Temperature	-40 ~ +85	°C
Tstg	Storage Temperature	-40 ~ +100	°C
Tsol	Soldering Temperature (for 3 seconds)	300	°C
Pd	Power Dissipation	120	mW
If (Peak)	Peak Forward Current (10% Duty Cycle, 10ms Pulse Width Max.)	100	mA

Electronic Optical Characteristics

Symbol	Parameter	Min.	Typ.	Max.	Unit	Condition	
Iv	Luminous intensity	198	320	445	mcd	If=20mA	
2θ½	Viewing Angle	—	130	—	deg	If=20mA	
Vf	Forward Voltage	—	3.6	4.0	V	If=20mA	
—	*Chromaticity Coordinates	x	.420	.440	.460	—	If=20mA
		y	.385	.405	.425		

* Per CIE 1931 Chromaticity Diagram.

Intensity Ranks

Symbol	Parameter	Rank	Min.	Typ.	Max.	Unit	Condition
Iv	Luminous intensity	S	198	295	393	mcd	If=20mA
		T	224	334	445		



Technical Specification

BOOTED SMT LED
WL-L2017B70C-003
Blue/White

Soldering Conditions

Soldering	Solder Dipping	Reflow Soldering
Soldering Iron: 20W Max Temperature: 300°C Max. Soldering Time: 3 Seconds Max.	Pre-Heat: 100°C Max. Pre-Heat Time: 60 Seconds Max. Solder Bath Temperature: 260°C Max. Dipping Time: 5 Seconds Max.	Pre-Heat: 120~150°C Pre-Heat Time: 2 Minutes Max. Solder Bath Temperature: 240°C Dipping Time: 5 Seconds Max. Conditions: Refer to Temperature Profile

Solder Pad Layout

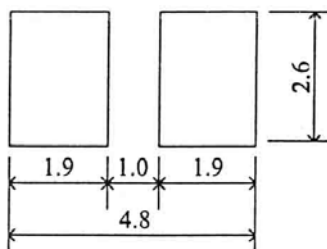

Temperature Profile

